

Attention: Please Read This Page

This presentation was originally given at the **OMG SBC Workshop** held in September of 2004. While we believe that the material is important and will be interesting to current users of Foresight Systems software, we have been through some changes since the paper was prepared.

Nu Thena Systems, Inc. was a predecessor company to Foresight Systems M&S. All references to Nu Thena are obsolete. Readers should assume that Foresight Systems M&S replaces all instances of Nu Thena Systems, Inc.

The current contact information for Foresight Systems M&S is:

Foresight Systems M&S
12550 N. 89th St.
Scottsdale, AZ 85260

<http://www.foresightsystems-mands.com>
fs_marketing@foresightsystems-mands.com

The diagrams and illustrations included here were prepared with versions of the software current at the time that the presentation was prepared. Some of them may not be identical to equivalent images from the current version of the software. We apologize for any potential confusion.

If you have questions, concerns, or issues, please contact:

Dean Stevens
President, Commercial Systems Group
Foresight Systems M&S
deans@foresightsystems-mands.com
(408) 278-3983

Performance Modeling and Simulation of the Co-development for Test Waveform and JTR Architecture



OMG SBC Workshop
Washington, DC
September 2004

Long V. Ho
Strategic Architecture Group
Integrated Defense Systems



Typical M&S Approach

- Descriptive Analysis
 - Problem formulation
 - Input source collection and analysis
 - Model development
 - Model verification, validation
 - Scenario simulation and performance evaluation
- Prescriptive Analysis and Post-prescriptive Analysis (Optional)
 - Calibration, goal seeking, Optimization and sensitivity testing
- Issues
 - Scope of the model
 - Specific questions to be answered by the M&S results
 - System configuration to be modeled
 - Performance measures that will be used to evaluate the efficacy of different system configurations
 - Time frame for the development and the required resources



Problem Formation

- Capability Verification
 - Verify that the capacity of the hardware architecture satisfies the operational need of the radio and waveform software for a particular JTR Set configuration
- Performance Analysis
 - Analyze end-to-end latency, component throughput, data and control bottlenecks meets resource loading and critical timing requirements
- Portability Validation
 - Validate that a particular waveform is properly partitioned
 - to match the capacity of the available hardware resources
 - to maximize software portability while satisfying application performance



Input Source Collection and Analysis

- Source Collection
 - Documents
 - SCA, API Supplements, Security Supplement, Developer's Guide
 - RTOS, CORBA
 - Waveform application specification
 - Radio application specification
 - JTR architecture specification
 - Estimate and measure performance parameters
- Source Analysis
 - Identify controllable and uncontrollable inputs.
 - Identify constraints on the decision variables.
 - Define measure of system performance.
 - Develop a preliminary model structure to interrelate the inputs and the measure of system performance

Model Development Roadmap

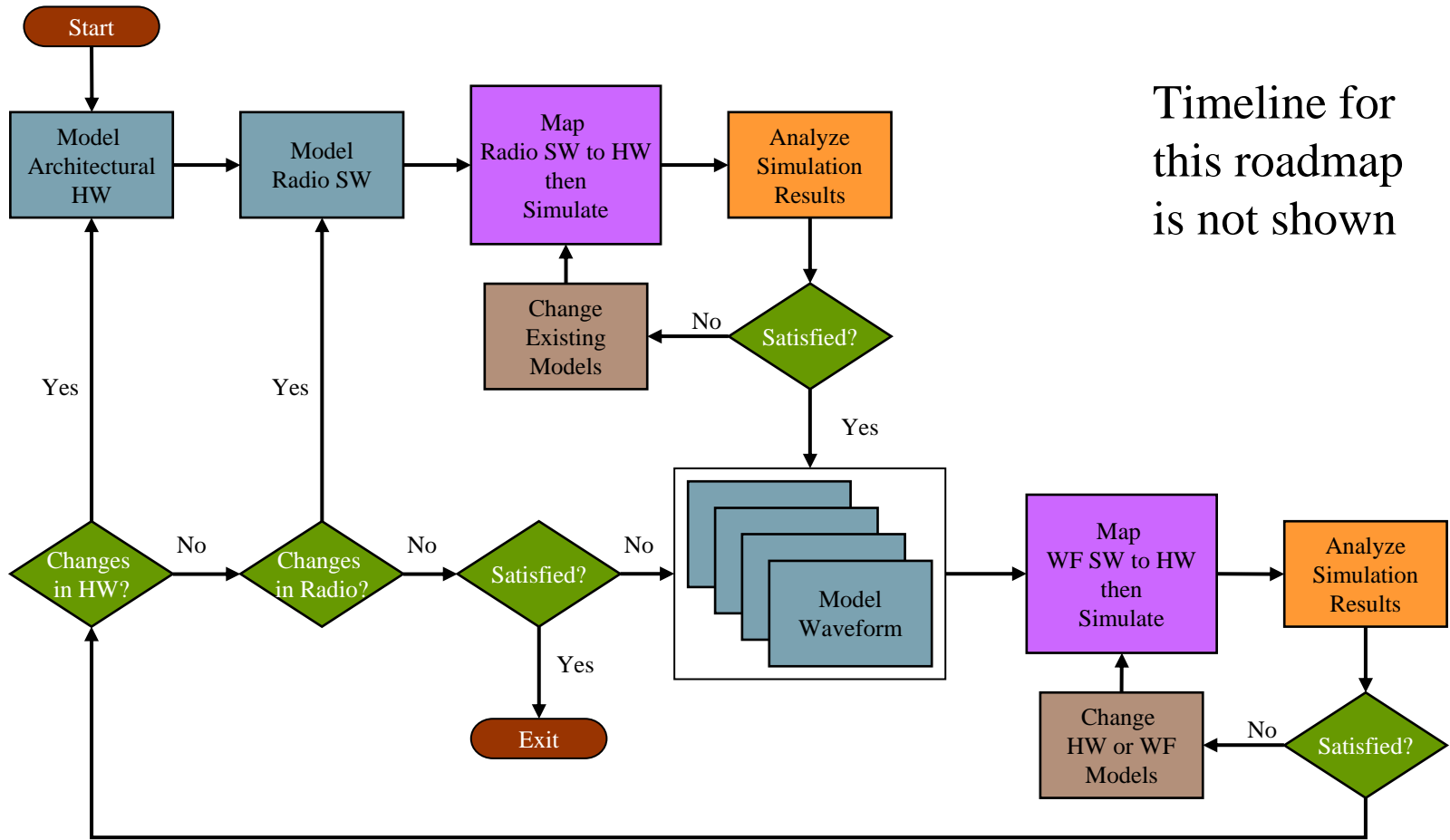

Timeline for this roadmap is not shown



Tool Selection

- Co-Design Tool by Foresight Systems
- Foresight – “A software product from Nu Thena providing graphical modeling tools for high level system design and simulation” – HyperDictionary.com
- The tool provides the two orthogonal views of the system – architecture and function – which are linked by a partitioning specification
- It also provide the system virtual prototype capability

Resource Mapping using Tool

Functional Software Model Diagram

Architectural Hardware Model Diagram

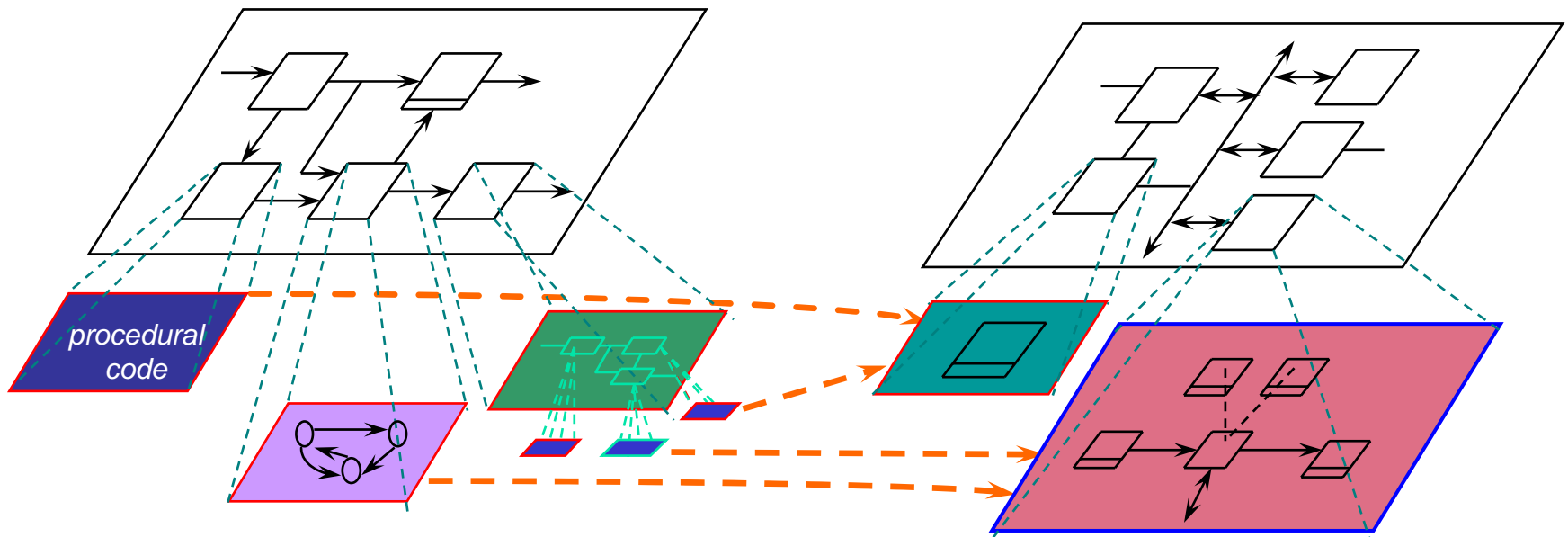

Mapping resource request of
Functions to Architecture



Modeling of Hardware Architecture

- The architectural model describes the hardware resources used in processing or transporting the radio and waveform application data
 - Create Models of Resource Building Blocks
 - Space-based and Time-based Resources
 - Build Models of HW Components
 - MEM, CPU, DSP, FPGA, I/O Devices
 - Build Models of HW Components and Architecture
 - Modem, Ethernet, Serial, Audio
 - Black, Red and Common General Purpose Processing (GPP)
- Inputs for M&S of hardware resources are hardware specifications
- Simulation parameters are component configuration, resource capacity



Space-based Resource Building Block

- A Basic Resource establishes the amount (capacity) of an asset available (e.g. memory) for all the competing processes to share.
- Foresight syntax to request a resource:
 - *aToken := requestRes (string name, real amount)*
 - *name* is a defined resource's name
 - *amount* is the amount of request (greater than zero)
 - *aToken* is an associated token with the request if successful. Otherwise, this token is a NOT_AVAILABLE token.
- Foresight syntax to release a resource that was requested:
 - *releaseRes (aToken)*



Time-based Resource Building Block

- A Process Resource establishes the work rate of an asset available (e.g. processor) for all the competing processes to share.
- Foresight syntax to request a resource:
 - *aResult* := ***requestProc*** (string *name*, real *amount*)
 - *name* is a defined resource's name
 - *amount* is the amount of request (greater than zero)
 - *aResult* is returned automatically AFTER process completes processing the requested amount. If preemption is desired a priority option may be supplied, then, *aResult* is an amount of resource that was requested but was not yet processed because of being preempted.

JTR Set Architecture

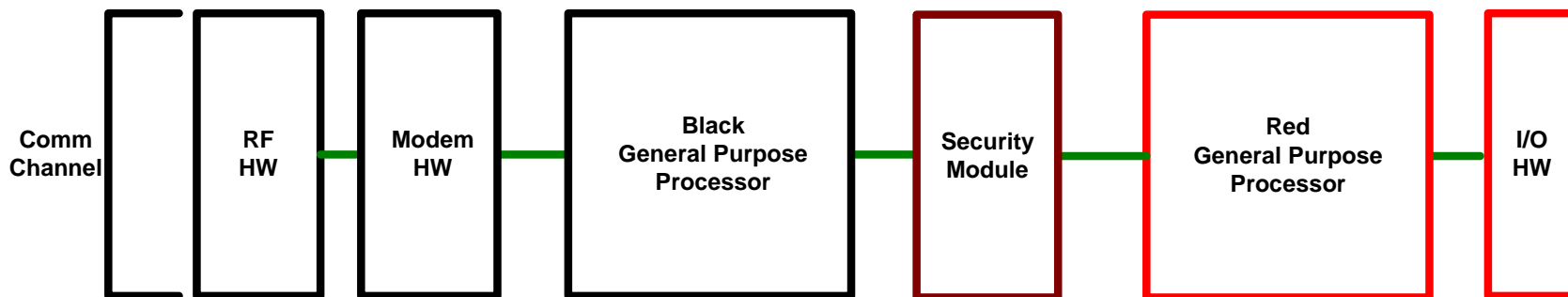



Modeling of Software Function

- The functional model describes the Radio and Waveform components and application that run on hardware resources
 - Create Models of Building Blocks
 - Generic Push Packet, Physical Real-Time, MAC, LLC, I/O
 - Build Models of SW Components
 - Radio Devices, Radio Services, Waveform Components
 - Build Radio and Waveform Application
 - Data Flow Diagram of Interconnected SW Components
- Inputs for functional models are radio and waveform functional specifications
- Simulation parameters are component configuration, resource utilization and latency performance

Radio State Model

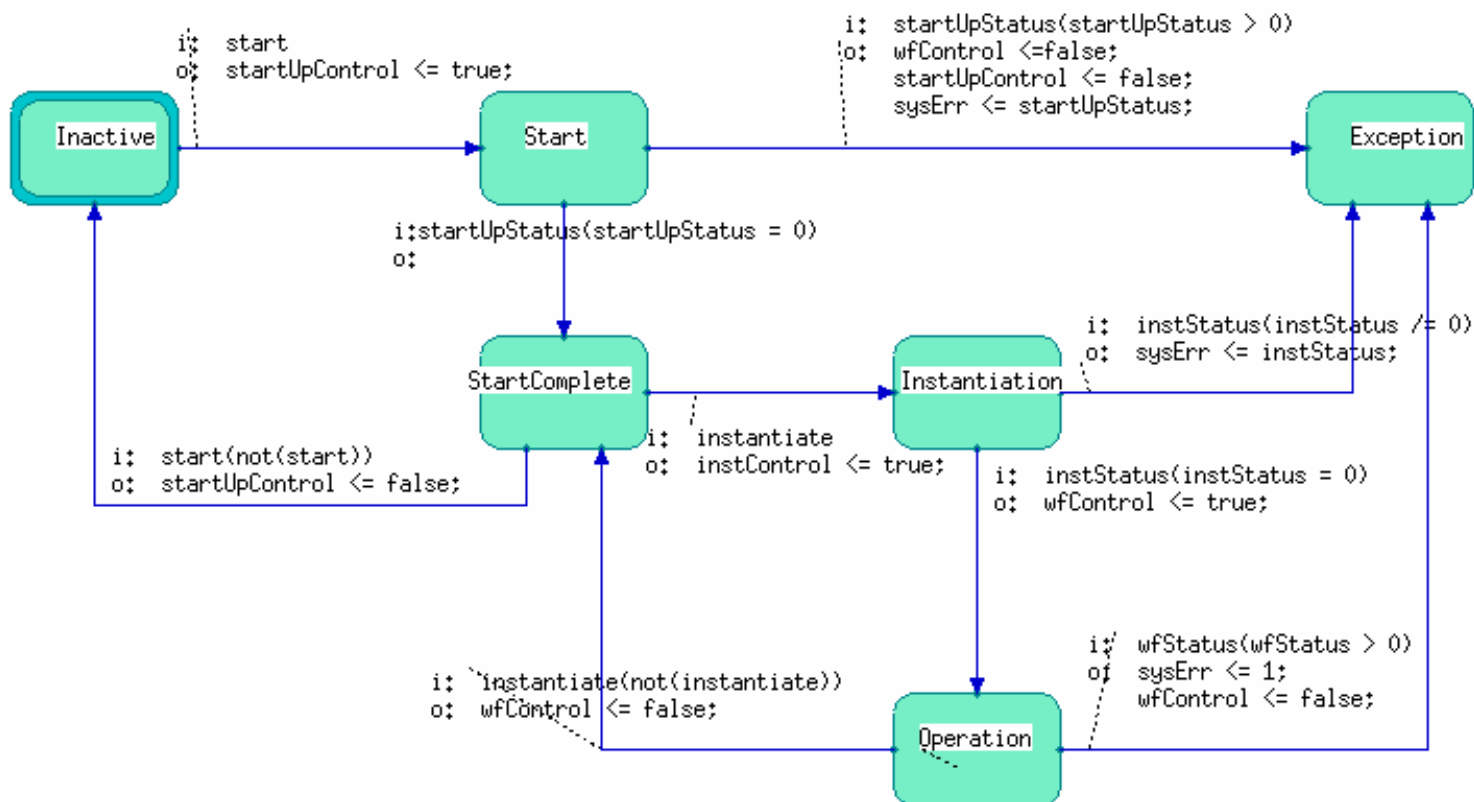

SCA Generic Packet API Building Block

- Based on SCA API Supplement Generic Packet Building Block (Appendix C)
- Provides a method to send user data between software entities and provides priority based flow control

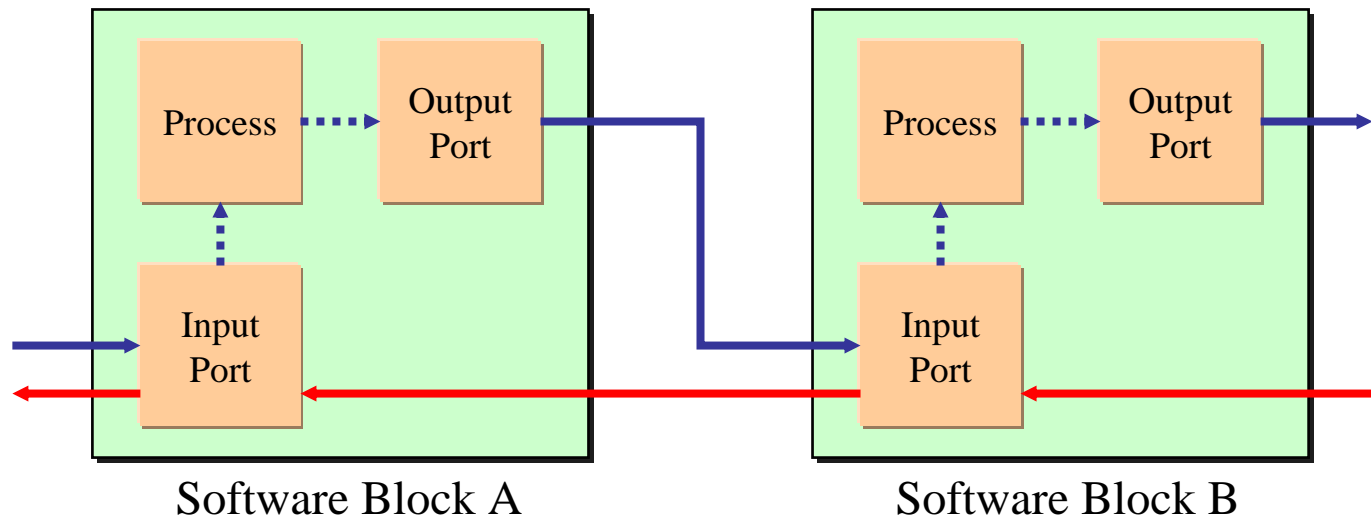

.....> Internal Data Flow (Small Latency)

————> External Data Flow (Large Latency)

←———— Control Flow

Push Packet API Model

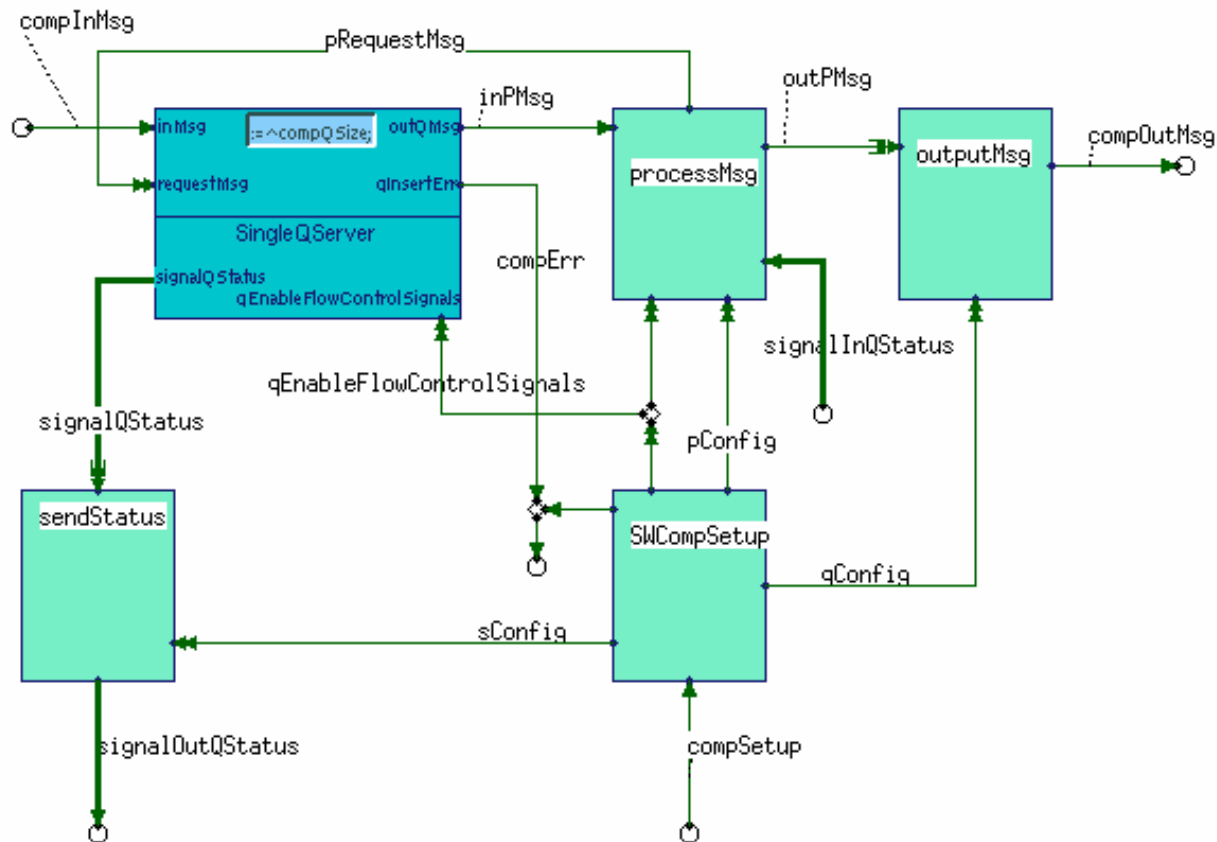

Radio and Waveform Application Control

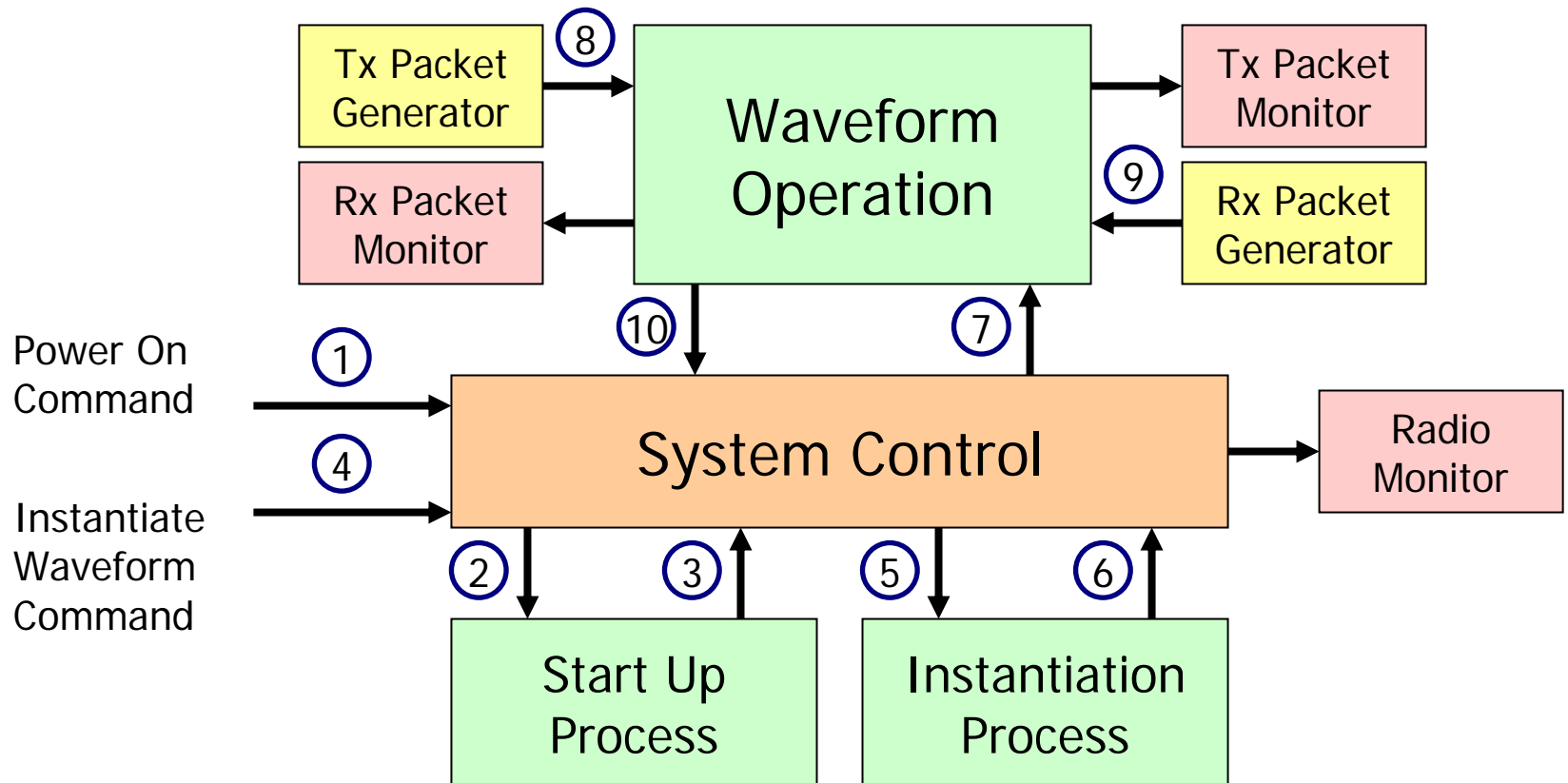

System Control Model

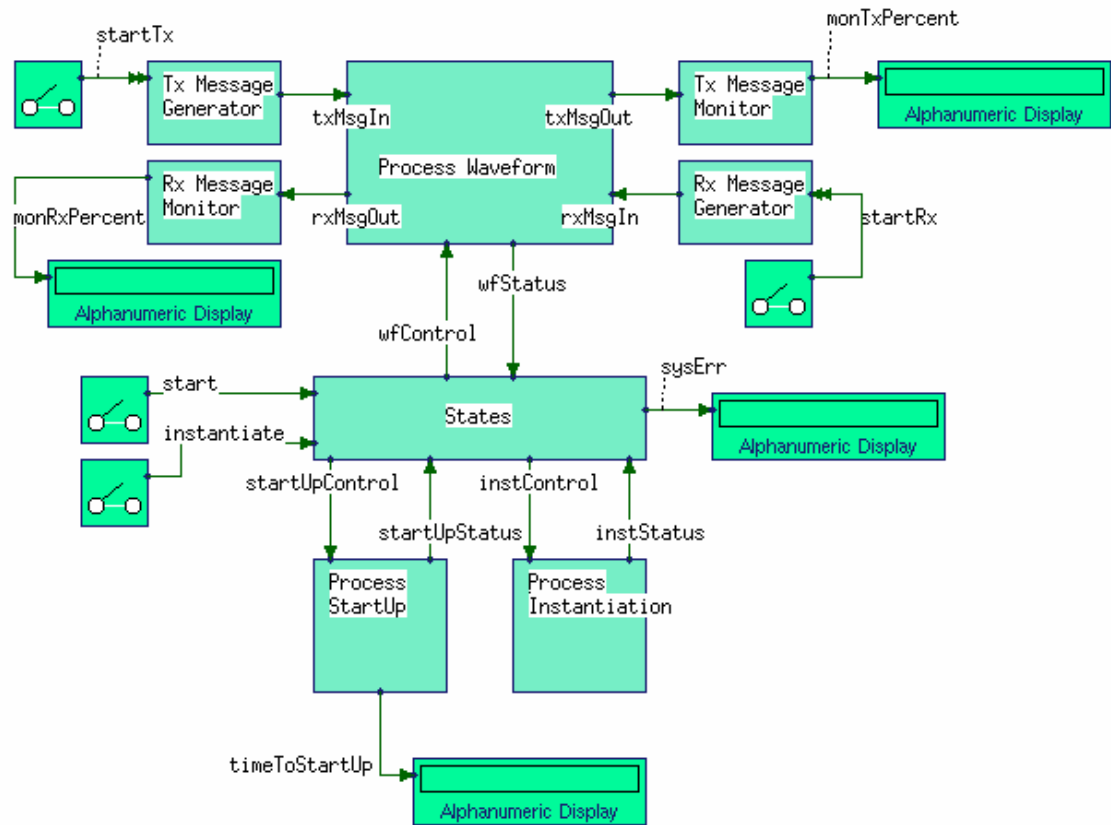

Test Waveform Modeling

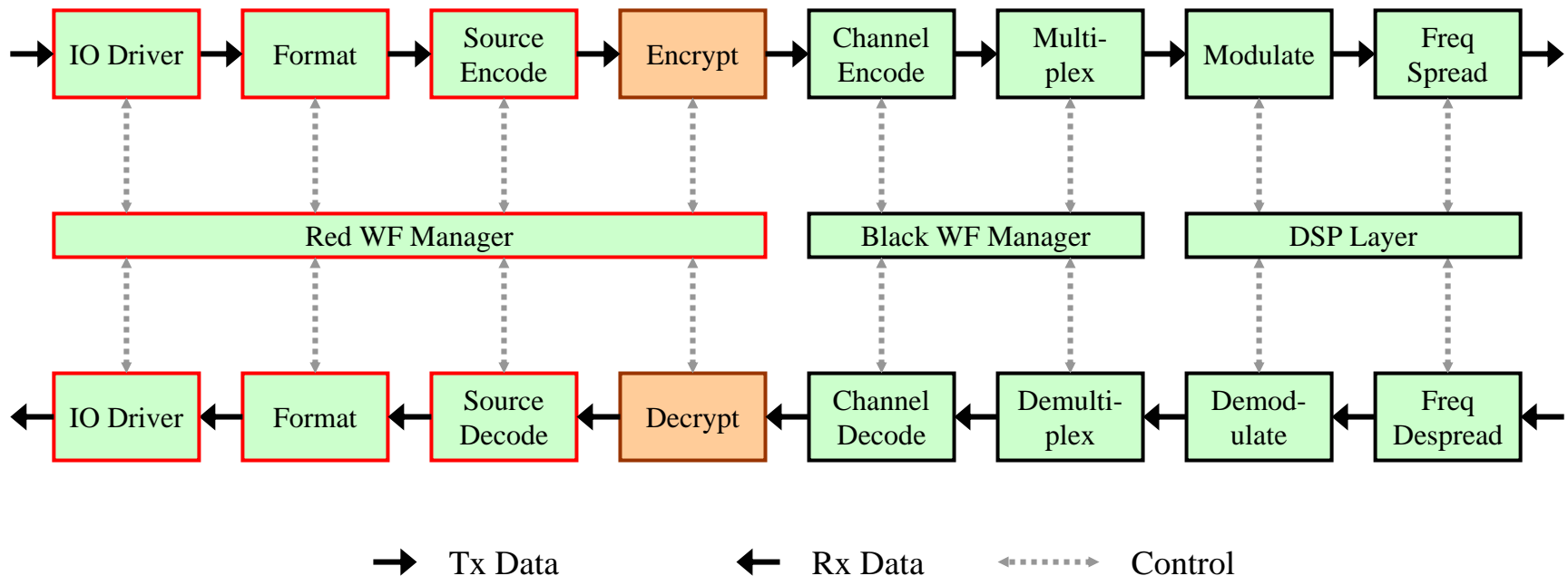

- Each block has zero to many CORBA and/or NON-CORBA Interfaces
- Transferring data among radio and waveform interfaces by message flows

Test Waveform Model

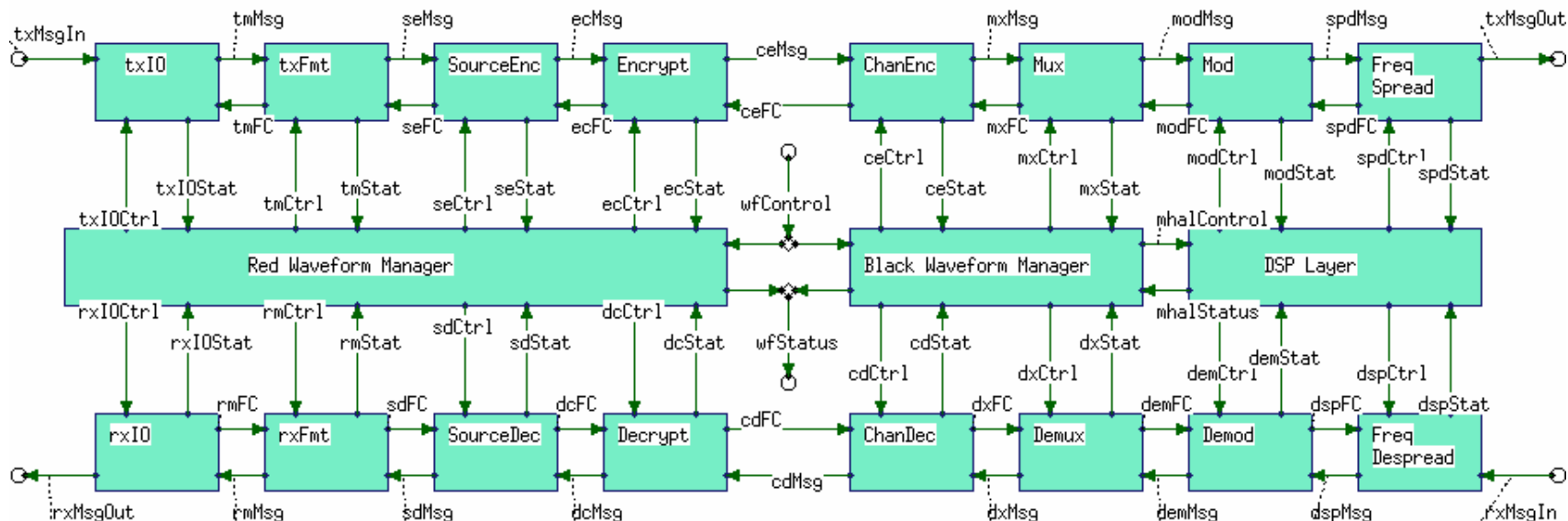



Verification, Validation and Calibration

- Verification checks the correspondence between the model and the reality
 - Unit testing of model component behaviors
 - integration test of system behaviors
- Validation focuses on the internal consistency of the model
 - Ensure each WF Application, Radio Service, Radio Device, Driver Components are modeled with proper component building blocks
 - Ensure models of SW and HW components matched their functional specification
- Calibration checks that the data generated by the simulation matches real (observed) data
 - Study and evaluate Input , In-process and Output data



Scenario Simulation and Performance Evaluation

- “Power On” command
 - The Start Up Process is triggered
 - Each GPP is boot independently, POST is proceeded, CF and radio software are loaded and started.
- “Instantiate Waveform” command
 - The Instantiation Process is started if the Start Up Process is successful. External data for resource mapping, utilization parameters, and Input/Output port configuration are passing via component’s configure ports.
- System enters Waveform Operation state after Instantiation Process is successful.
 - Start message generator
 - Monitor packet throughput (loss) and latency, resource usages
- Evaluate various strategies for the operation of this waveform



Conclusion

- Early Evaluation of Waveforms and Radio Sets results in lower risk and reduced cost
 - Evaluate the performance effectiveness of resource allocations for JTR system
 - Identify resource bottlenecks
 - Evaluate the probability of waveform/task execution success (as it relates to resource availabilities) for each waveform class, under priority based resource sharing and allocation policies
- Future Work
 - Make use of Domain Profile to configure model for simulation
 - Model additional APIs from SCA Extensions



Demonstration
